

Sunflower Art Cost Estimate

August 21, 2020

Description	Amount
Design ¹	4,285
Building Reinforcement ²	13,040
Reinforce sculpture, powder coat, install ³	29,700
Sub-Total	47,025
Contingency @ 15%	7,054
Sub-Total	54,079
NMGRT	3,955
Total Project Cost	58,033

1. Expended
2. Based on Engineer's Estimate
3. Based on quote

Sunflower at Black Hole:



Sunflower in current state (5/2019):



Sculpture Smart Estimate (Joe Lindsay)

Scope of work-deliverables

- 1) Drawings for brackets (wall attachment and sculpture attachment), installation details, site visits
- 2) Engineering clearance
- 3) Transport
 - Pick up from site, bring to shop
 - Take to powder coater
 - Take from powder coater to site
- 4) Work in shop to cut, grind , drill, welding, cutting steel plate.
- 5) All Materials, bracket materials, steel circle, bolts, attachment system
- 6) Powder coating
- 7) Rental of crane to lift sculpture
- 8) Rental of lift to install bracket fittings on wall, and install sunflower to bracket
- 9) Installation of sculpture

\$25,200

Powder coating includes heavy zinc primer
All welds by certified welder
Liability insurance for all phases of work

With sculpture painted vs powder coating \$21,200
With sculpture re-welded as in Steven's drawings \$29,700

**** Job would be outside of Sculpture Smart's current contract****

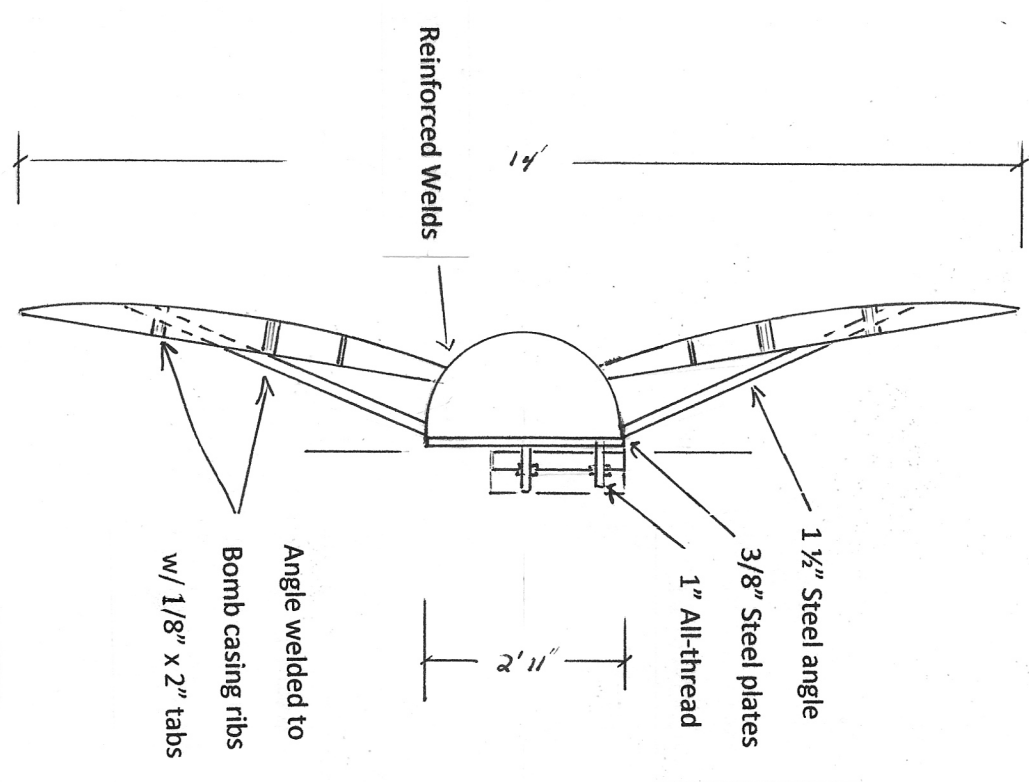
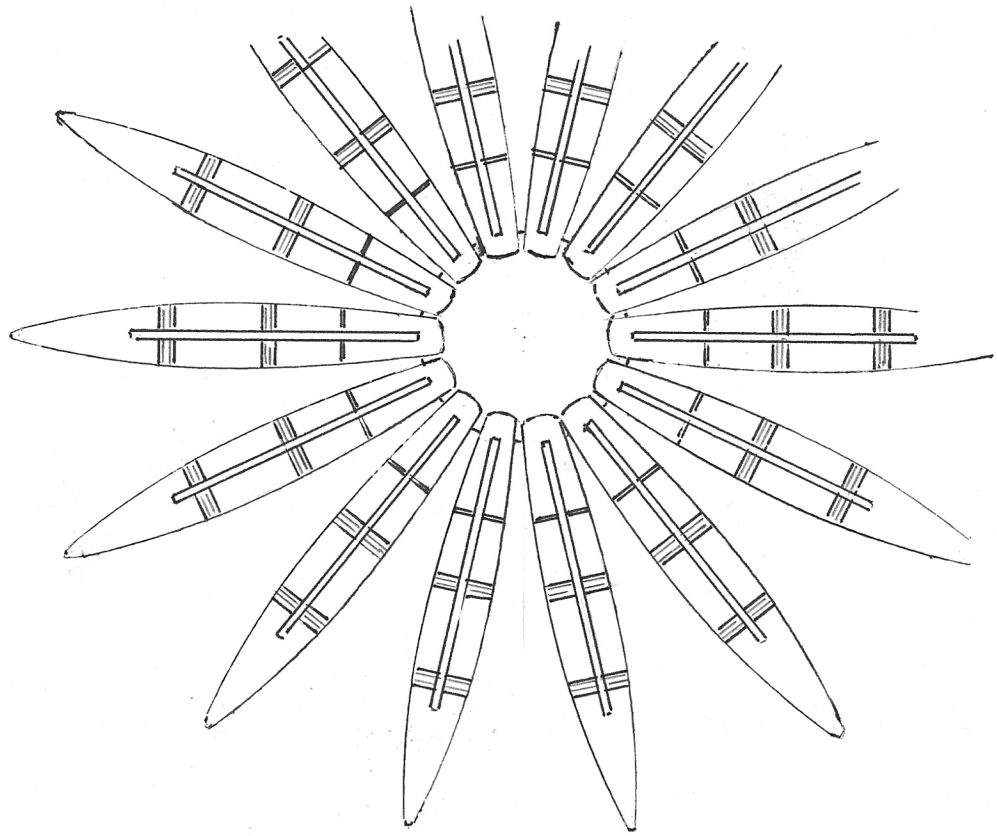

Attachment A

Project Sunflower sculpture rebuild

Scale NTS Date June 8, 2020

